

ID13_Daily energy management system for a house powered by renewable energy

Samir Arfa^{*1}, Mohsen Ben Ammar¹, Mohamed Ali Zdiri¹

Hsan Hadj Abdallah¹

^{*}CEM Laboratory¹, ENIS (National Engineering School of Sfax), Tunisia
University of Sfax, Sfax Engineering School, BP 1173, 3038 Sfax, Tunisia

^{*}arfa.samir@gmail.com

mohsen.benammar@enis.tn, mohamed-ali.zdiri@enis.tn,
hajabdallahhsan@gmail.com

Abstract— The basic idea of this work is to create an electrical energy management system of a real daily domestic load located off the electrical grid. This house will be powered by a wind turbine with variable wind speed as a renewable energy source coupled to a permanent magnet synchronous machine PMSG as a generator, a battery storage and a diesel generator in case of need. The studied system is validated by a simulink simulation under the Matlab software. The results obtained confirm the effectiveness of the system used.

Keywords—wind turbine, battery, domestic load, diesel generator, energy management.

I. INTRODUCTION

Energy production is a challenge of great importance for the future [1-2]. Indeed, the consumption of fossil fuels leads to greenhouse gas emissions and therefore an increase in pollution. Faced with the multiple economic and oil crises, science has turned its attention to the so-called renewable resources, which constitute a strategic sector and occupy a privileged place in the field of research and development [3].

Energy management is a very broad concept that refers to the set of rules for managing the transfer and exchange of energy between the generation and the variable consumption of the load [3]. This management allows the reliability and the good distribution between the renewable source, the storage system, the diesel generator and the load, by providing adequate commands to the various converters, in order to ensure a permanent supply of the load and to increase the life of the various components by following well defined techniques [3, 5, 8, 10]. In recent years, power management has tended to expand into many different areas. According to the study of several researchers' works, the power management strategy is based on several methods such as the battery state of charge (SOC) [12], the SOC with the level of absorbed or supplied power [13], the techno-economic study of the application used [14].

Today, wind energy occupies a very important place in the renewable energy sector [4]. In this context, wind energy

is used to supply an isolated site equipped with a storage system in the event that the energy produced is greater than that required. To ensure the autonomy of this site we use a diesel generator.

This work is organized in five sections. After the introduction, we present in the second section the modeling of the studied chain. The third section describes the energy management algorithm of the different sources. Then we present the results of the obtained simulation. We finish this work with the conclusion.

II. MODELING THE STUDIED SYSTEM

The system used in this paper consists of a variable speed wind turbine as a renewable energy source, coupled to a synchronous generator with permanent magnet PMSG, a battery for energy storage in case of excess and a generator mode in case of lack. The site has a diesel generator used in case of emergencies (lack of wind and battery discharge). The wind turbine and the battery are connected with a continuous bus. The synoptic diagram of the system studied is given in the following figure:

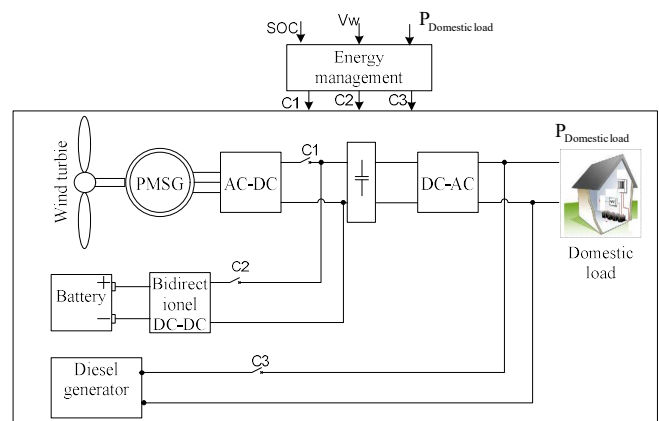

Fig. 1. Synoptic of the system studied

1) Wind Turbine modeling

Wind energy is the conversion of wind power into mechanical energy, electrical energy or kinetic energy. The power recoverable by a wind turbine is a function of the square of its diameter and the cube of the wind speed [3]:

$$P_W = C_p \rho \pi R^2 V_W^3 \quad (1)$$

$$\lambda = \frac{R\Omega}{V_W} \quad (2)$$

2) PMSG modelling

The permanent magnet synchronous machine is more used in small applications to produce wind power. In this case the PMSG is a generator with radial magnetization. So the model will be represented by to a smooth pole machine with $L_{sd} = L_{sq} = L_s$. The PMSG is shown in figure 2:

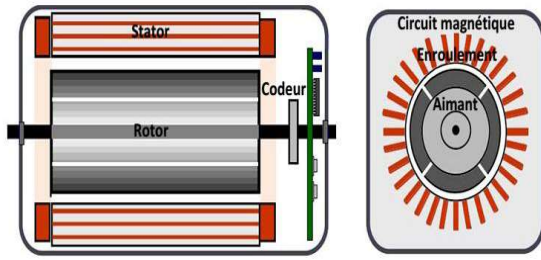

Fig. 2. PMSG scheme

In the Park reference, the PMSG is modeled by the following equations [3, 9]:

$$V_{sd} = R_s I_{sd} + L_s \frac{dI_{sd}}{dt} - p\Omega L_s I_{sq} \quad (3)$$

$$V_{sq} = R_s I_{sq} + L_s \frac{dI_{sq}}{dt} + p\Omega L_s I_{sd} + p\Omega \Phi_m \quad (4)$$

$$J \frac{d\Omega}{dx} = T_m - T_{em} - f\Omega \quad (5)$$

The expression of electromagnetic torque of the PMSG is:

$$T_{em} = p\Phi_m I_{sq} + (L_{sq} - L_{sd}) p I_{sd} I_{sq} = p\Phi_m I_{sq} \quad (6)$$

The equation of active power of the generator PMSG:

$$P_{gen} = i_{sd} V_{sd} + i_{sq} V_{sq} \quad (7)$$

3) Storage system (Battery)

The battery is modeled by the following circuit:

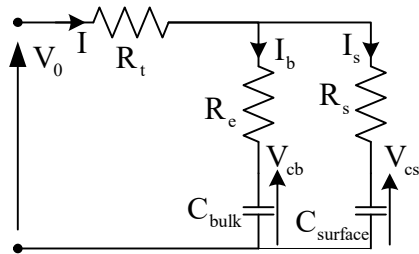

Fig. 3. Battery model diagram

Then the state model of the battery used in this work is represented by the following expression [5]:

$$\dot{X} = [A]X + [B]I \quad (8)$$

$$X = [V_{cb} \quad V_{cs} \quad V_o]^T$$

$$[A] = \begin{bmatrix} \frac{1}{C_{bulk}(R_e + R_s)} & \frac{1}{C_{bulk}(R_e + R_s)} & 0 \\ \frac{1}{C_{surface}(R_e + R_s)} & -\frac{1}{C_{surface}(R_e + R_s)} & 0 \\ A(3.1) & 0 & A(3.3) \end{bmatrix} \quad (3.3)$$

$$[B] = \begin{bmatrix} \frac{R_s}{C_{bulk}(R_e + R_s)} \\ R_e \\ \frac{C_{surface}(R_e + R_s)}{A} \end{bmatrix}$$

With :

$$A(3.1) = -\frac{R_s}{C_{bulk}(R_e + R_s)^2} + \frac{R_e}{C_{surface}(R_e + R_s)^2} - \frac{R_s^2}{C_{bulk}R_e(R_e + R_s)^2} + \frac{R_s}{C_{surface}(R_e + R_s)^2}$$

$$A(3.3) = \frac{R_s}{C_{bulk}R_e(R_e + R_s)} - \frac{1}{C_{surface}(R_e + R_s)}$$

$$A = \frac{R_s}{C_{surface}(R_e + R_s)^2} - \frac{R_s R_t}{C_{bulk}R_e(R_e + R_s)^2} + \frac{R_t}{C_{surface}(R_e + R_s)} + \frac{R_t}{C_{surface}(R_e + R_s)^2}$$

In this work, we have used lead-acid battery to store the excess energy generated from the WT. The battery charge (Q_{bat}) can be obtained with the following equation [11].

$$Q_{bat} = Q_{bat-i} + \int_0^t V_{bat} I_{bat} dt \quad (9)$$

With Q_{bat-i} is the initial battery charge, I_{bat} and V_{bat} are respectively current and voltage of the battery.

4) Diesel generator

The diesel generator is commonly used in several applications. It is often used as a backup source in a hybrid system based on renewable energies in isolated mode. It intervenes to cover the lack of power ensuring the continuous supply of the load and the energetic stability of the system [3].

5) Boost converter modeling(DC-DC)

In this case we will be interested a DC-DC converter for a better adaptation between the wind and the battery. The converter might control to yield constant output DC voltage level. The electrical circuit of the boost converter is shown in the figure following [4].

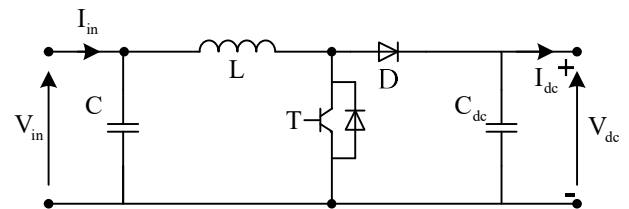

Fig. 4. The model of boost converter.

The transfer function of the used converter is given by equation following:

$$V_{dc} = \frac{V_{in}}{1-D} \quad (10)$$

With: D denotes the duty cycle.

6) **Domestic load**

In this work, we will use a real load profile. This load will be a domestic load that models the daily consumption (24 hours) of a house. This domestic load profile contains three peaks of energy consumption morning, noon and night. This daily load varies between 1.5 KW and 3.5 KW.

7) **System simulink model**

The modelling of the studied system in Matlab/Simulink is shown in figure 5.

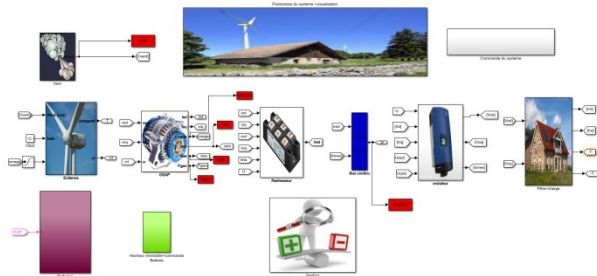

Fig. 5. Simulink model of chain

III. POWER MANAGEMENT ALGORITHM OF THE SYSTEM

The algorithm of management and energy exchange between the different parts of the system [8] is modeled by the following figure.

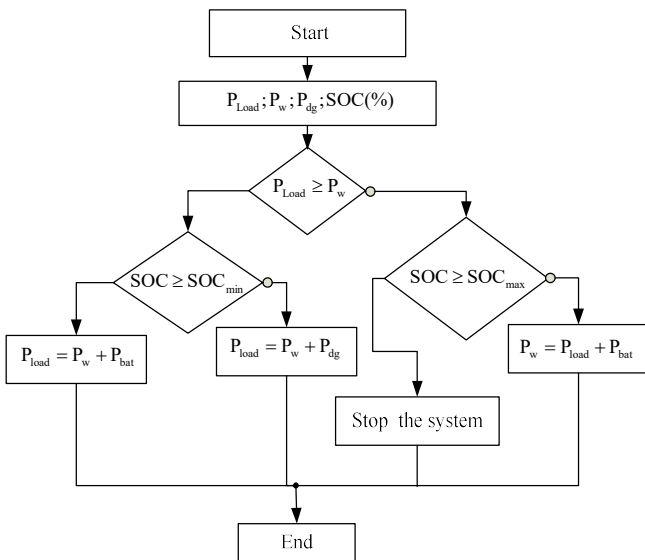

Fig. 6. Algorithm de gestion

The principle of this algorithm is to compare the energy generated by the energy demanded by the domestic load. Then to check the SOC level of the battery, whether it is minimum in discharge mode feeding the load, or maximum, in charge mode of the battery by the wind turbine.

IV. RESULTS STUDY

This paragraph is dedicated to the simulation results of our system. The angular speed and the electromagnetic torque of the synchronous machine are represented by the following figure 7 and figure 8. The power generated by the wind turbine is given by figure 9. The figure 10 shows the logical state of the managed switches of the studied chain and figure 11, 12 shows the power balance after the energy exchange management.

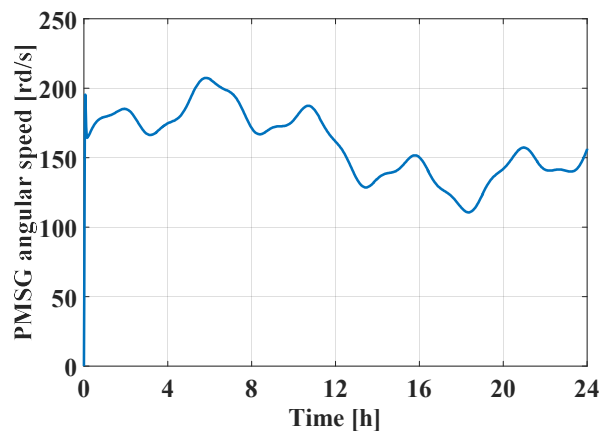

Fig. 7. PMSG angular speed

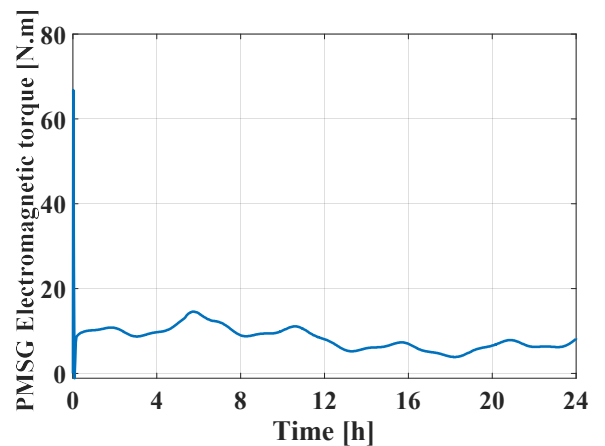

Fig. 8. Electromagnetic torque

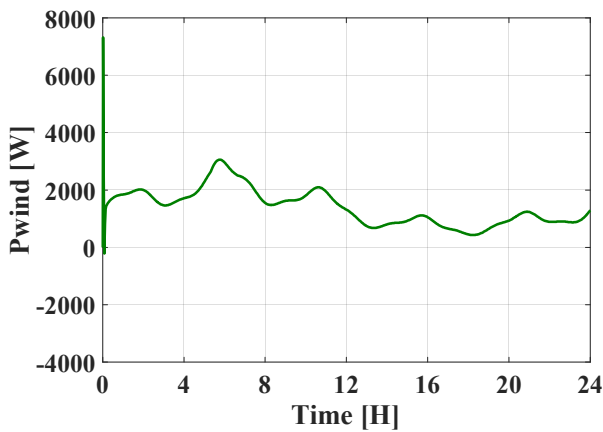

Fig. 9. Wind turbine power

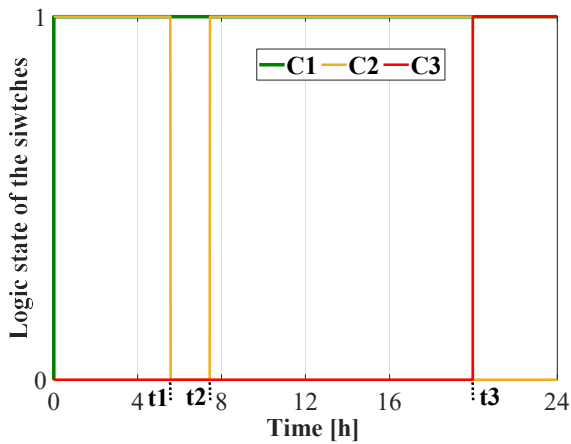

Fig. 10. Logical status of the management switches

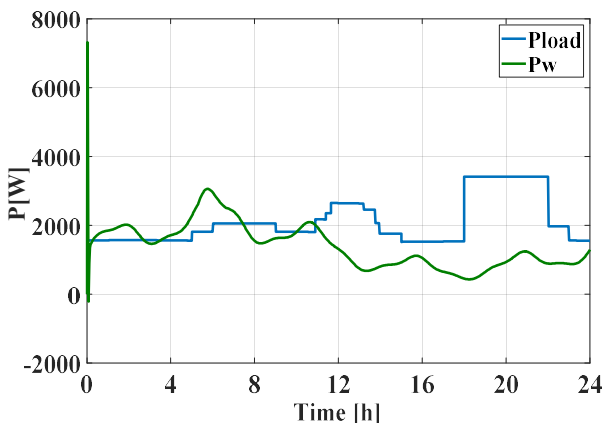

Fig. 11. Domestic load power

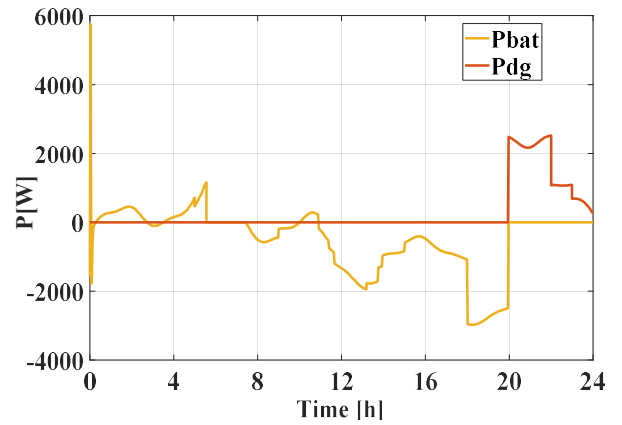

Fig. 12. Evolution of daily energy management

The figure 10 shows the status of the management system switches, at time t_1 the energy developed by the WT is greater than the load and the battery has reached the maximum threshold at this time the battery will be disconnected. At time t_2 , the energy generated by the WT is less than the load; in this case, the WT and the battery work together to provide the required energy. We notice that at t_3 (20h) the battery is totally discharged. In this situation the management system calls the connection of the diesel generator to cover the energy need.

The interpretation the figure 11 and 12 shows us that if the power developed by the wind turbine is greater than that of the domestic load, in this case the excess is stored in the battery. In the opposite case the wind turbine and battery supply the load.

The state of charge of the battery (SOC) is represented by the figure 13. The minimum charge level of the battery is 30%, while the maximum level is 90%. During the whole day the battery is charged and discharged only once, thus extending the battery life.

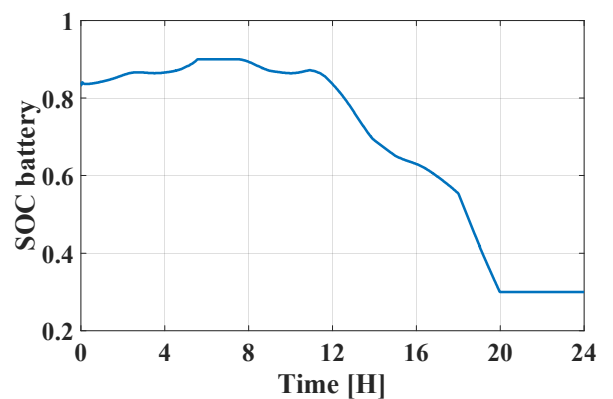

Fig. 13. State of charge of the battery

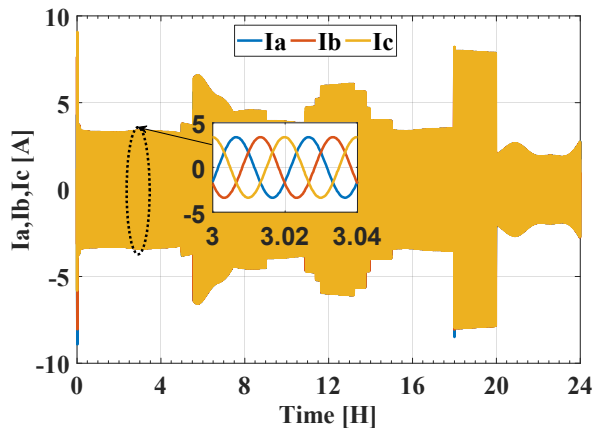

Fig. 14. The domestic load currents

We also notice that the load currents (figure 14) are sinusoidal and the frequency is 50 Hz.

V. CONCLUSION

In this work, we succeeded in creating an energy management algorithm for a variable domestic load. This site includes a variable speed wind turbine to produce electrical energy, a battery to store energy and a diesel generator as a backup source.

The simulation results found in this work by Matlab Simulink validate our multi-source system studied.

The perspectives of this work, we must find a solution in the case where the generated energy is greater than the load and the battery reaches the maximum load threshold and use intelligence control of electronic converters used.

Table. PMSG parameters.

Description	Value
P (Rated power in kW).	3
J (Moment of inertia in kg.m ²).	99e ⁻⁴
p (Number of pole pairs)	4
R _s (Resistance in Ω).	0.82
L _s (Stator inductance in H).	15e ⁻³
f (Friction factor in N.m.s.rad ⁻¹).	1 e ⁻³
Φ _m (Magnetic flux of magnets in Wb)	0.5

NOMENCLATURE AND ABBREVIATIONS

V_w: wind speed (m s⁻¹)
 ρ : air density (1.22 Kg m⁻³)
 P_w: wind power (W)
 C_p: the power coefficient of the wind turbine
 R: length of the blade (m)
 Ω: angular speed (rad.s⁻¹)
 P_{dg}: Power of diesel generator (W)
 P_{bat}: battery power (W)
 P_w: power extracted from the wind (W)
 V_{sd}, V_{sq}: stator voltages in Park frame (V)
 V_{rd}, V_{rq}: rotor voltages in Park frame (V)
 I_{sd}, I_{sq}: stator currents in Park frame (A)
 I_{rd}, I_{rq}: rotor currents in Park frame (A)
 R_s: stator winding resistance (Ω)
 L_{sd}: stator winding inductance (H)
 L_{sq}: stator winding inductance (H)
 φ_m: Permanent magnetic rotor flux (Wb)
 T_e: electromagnetic torque (N.m)
 PMSG: Permanent Magnetic synchronous Generator
 SOC: state of charge the battery
 C_{bulk}: volume capacity battery (F)
 C_{surface}: surface capacity (F) battery
 R_e: end resistance battery (Ω)
 R₀: surface resistance battery (Ω)
 R_t: terminal resistance battery (Ω)
 C1: starting and stopping wind turbine
 C2: starting and stopping battery
 C3: starting and stopping diesel generator

References

[1] Y. Zhang, H. Sun, and Y. Guo, "Integration Design and Operation Strategy of Multi-Energy Hybrid System Including Renewable Energies, Batteries and Hydrogen", *Energies*, vol. 13, 5463, 2020.

[2] N. Yimen, T. Tchotang, A. Kanmogne, and I. Abdelkhalikh Idriss "Optimal Sizing and Techno-Economic Analysis of Hybrid Renewable Energy Systemsa Case Study of a Photovoltaic/Wind/Battery/Diesel System in Fanisau, Northern Nigeria". *Processes*, vol. 8, 1381, 2020.

[3] A. Abdelkafi, A. Masmoudi, and L. Krichen, "Assisted power management of a stand-alone renewable multi-source system". *Energy*, vol. 145, pp. 195-205, .2018.

[4] K. Ghaib, and F.Z. Ben-Fares, "A design methodology of stand-alone photovoltaic power systems for rural electrification", *Energy Conversion and Management*, 148, pp. 1127–1141, 2017.

[5] C. Ben Salah and Mohamed Ouali. "Energy management of a hybrid photovoltaic system", *INTERNATIONAL JOURNAL OF ENERGY RESEARCH. Int. J. Energy Res.* 36 pp. 130–138. 2012.

[6] A. Khiareddine, C. Ben Salah, Mohamed Faouzi Mimouni. "Power management of a photovoltaic battery pumping system in agricultural experiment station". *Solar Energy* 112, pp. 319–338. 2015.

[7] B. Thirumalai samy, "Modeling and simulation of stand-alone hybrid power system with fuzzy MPPT for remote load application". *ARCHIVES OF ELECTRICAL ENGINEERING. VOL. 64(3)*, pp. 487-504 (2015).

[8] M. F. Almi, M. Arrouf, H. Belmili, S. Boulouma, B. Bendib, "Energy management of wind/PV and battery hybrid system". *International Journal of New Computer Architectures and their Applications (IJNCAA)* 4(1): 30-38 , 2014

[9] M. Smaoui, Lotfi Krichen, "Control, energy management and performance evaluation of desalination unit based renewable energies using a graphical user interface". *Energy* 114 (2016), pp. 1187-1206.

[10] M. Koulali, "Energy Management of Hybrid Power System PV Wind and Battery Based Three Level Converters". *TECNICA ITALIANA- Journal of engineering science.* Vol. 63, No. 2-4, June, pp. 297-304, 2019.

[11] H. Rezk, M. Al-Dhaifallah, Y. B Hassan, & H. Ziedan, "Optimization and Energy Management of Hybrid Photovoltaic-Diesel-Battery System to Pump and Desalinate Water at Isolated Regions", *IEEE Access*, pp. 102512-102529, 2020.

[12] K. Zhou, J.A. Ferreira, S.W.H. de Haan, "Optimal energy management strategy and system sizing method for stand-alone photovoltaic-hydrogen systems". *International Journal of Hydrogen Energy*, vol.33, pp.477-489, 2008.

[13] R. Dufo-López, J.L. Bernal-Agustín, "Design and control strategies of PV-Diesel systems using genetic algorithms", *Solar Energy*, vol.79, pp.33-46, 2005.

[14] R. Carapellucci, L. Giordano, "Modeling and optimization of an energy generation island based on renewable technologies and hydrogen storage systems", *International Journal of Hydrogen Energy*, vol.37, pp.2081-2093, 2012.